

Haier

Air Cooled Module Water Chiller

Installation, operation and technical manual



Heat pump / Cooling only

R22 refrigerant

33KW, 65KW

3PH, 380V~400V, 50Hz

Haier Commercial Air Conditioning

MODEL: SYJS-012-06REV.0

2006-5-10



Большая библиотека технической документации

<https://splitsystema48.ru/instrukcii-po-ekspluatácii-kondicionerov.html>

каталоги, инструкции, сервисные мануалы, схемы.

TABLE OF CONTENTS

1. Nomenclature.....	3
2. Product character.....	3
3. Specifications.....	5
4. Dimension data.....	7
5. Installation and debugging.....	8
6. Safety precaution.....	9
7. Refrigerant circuit.....	10
8. Water system installation diagram.....	11
9. Auxiliary electric heating function control.	12
10. Water pump operation control(valid when water pump and the unit controlled simultaneously).....	12
11. The terminal simultaneous control.....	12
12. Wiring diagrams.....	13
13. Wired controller functions.....	15
14. Operation introduction.....	19
15. External wiring of UHR-820 type control board.....	22
16. Control functions.....	23
17. Controller specs.....	25
18. Malfunction and troubleshooting.....	25
19. Water quality management.....	26
20. Daily maintenance.....	26

1. Nomenclature

Code Explanation for chiller

1	2	3	4	5	6	7	8	9	10					
Chiller system	Compressor type	Capacity (KW)				Product type		Unit character	Suitable voltage	Design number				
C	Hermetic scroll	A	1	0	6	Heat pump	R22	A	Air cooled	A	100-115V/60Hz	1	Fixed frequency	A-G
	Hermetic rotary	B	0	2	3		R407C	B	Water cooled	W	220-240V/50Hz	2	Inverter	H-Q
	Hermetic single screw	C	0	0	1		R134a	C			100V/50Hz	3	DC inverter	R-Z
	Hermetic twin screws	D					R123	D			220V/60Hz	4		
	Hermetic reciprocating	E				Cooling only	R22	M			110V/50-60Hz	5		
	Hermetic absorption	F					R407C	N			220V/50-60Hz	6		
	Semi-hermetic scroll	G					R134a	P			127V/60Hz	7		
	Semi-hermetic single screw	H					R123	Q			240V/50Hz	8		
	Semi-hermetic twin screws	I									110-220V/50-60Hz	9		
	Semi-hermetic reciprocating	J								380-400V/50Hz	N			
	Semi-hermetic absorption	K								415V/50Hz	M			
	Semi-hermetic centrifugal	L												
	Opened	M												

2. Product character

- Installation conveniently, no need the special machine room and water tower; can be installed on the roof or out of the room. Widely application for cinema, hospital, hotel, school, commercial building, etc.
- Utilize flexible scroll compressor. And adopts dual compressors in parallel technology. The master unit will control both compressors run or stop due to the water outlet temp. Optimum refrigerant distribution technique and minimum-deformation design. Adoption of rolling bearing and non-lubricated bearing. Excellent heating effect at low temperature. Broad range of working temperature and suitability for high condensation temperature.
- Shell & Tube and U type inner grooved finned coil heat exchanger.
High efficient water side heat exchanger: in cooling, the water side heat exchanger is as evaporator; in heating, it is as condenser. The freezed water flows outside of the pipe, and the refrigerant flows in the pipe. Optimum design, reliable operation, reasonable structure, perfect performance.
- Central control technology, indoor unit be connected with controller by dual core non-polar wire. The indoor units can be controlled individually or simultaneously, more convenient, more energy saving. One central air conditioning system can include max. 8 sets (65 series) or 16 sets (100 series) of module unit. Through the dip switch on PCB you can set unit No. of every module unit, and every unit is connected by RS485 port. Compact structure, convenient for electric installation.
- Fan coil simultaneous control technology: indoor fan coil can be controlled individually or centrally.

Every indoor unit is connected to the individual controller or central controller through dual-core non-polar wire to realize the central control. When one indoor starts up, the central air conditioning system will start up automatically. When all indoors arrive the set temperature, the master unit will stop. Energy saving.

- f. Auto check technology: The system can check the operation status automatically; all kinds of sensors will transmit the operation parameters to the chip. By pressing the buttons, all the parameters can display on the liquid crystal screen. When the unit occurs failure in operation, the failure will display on the LED so that the malfunction can be solved soon.
- g. Password control function: According to the user setting, the password control function can be used. Therefore the control to the unit will be more reliable and more flexible.
- h. Equipped with RS-485 physical connector, perfect network communication ability.
- i. Module structure design, the system can be produced or transported as module unit. Every system is independent, and they are spare part for each other, however which cooling circuit is abnormal, the other systems do not be affected by the abnormal system, and furthermore they will run in shape. Module structure can reduce the cost of transport and installation greatly, more convenient.
- j. Heat exchanger of air side is designed much larger, enlarge heat transmission area, lower the temperature drop of transmission. Consequently, the chiller can run in cool mode even at high temperature of 45celsius degree in summer, and also can run in heat mode at low ambient temperature of -15celsius degree in winter with good performance.
- k. Safety and protection devices: phase reverse protection device, high and low pressure switch, freeze protection device, overheat protection device, overload protection device, etc. Also, with Timer ON/OFF, AUTO operation, defrosting, etc. functions.

3. Specifications

Model			CA0035AANB/CA0035MANB	CA0070AANB/CA0070MANB
Nominal cooling capacity		KW	33	65
Nominal heating capacity		KW	35 (only for CA0035AANB)	70 (only for CA0070AANB)
Total power input		KW	10.1	20.2
Start current		A	142	142
Running current		A	17.5	35
Max. running current (in the electric control box)		A	22.5	45
Recommended circuit breaker		A	6A 500V	6A 500V
Power supply			3PH, AC380V, 50Hz	3PH, AC380V, 50Hz
Number of power supply circuit			1	1
Running control method			fully automation	fully automation
Appearance colour			ivory white	ivory white
Capacity control step			1	2
Safety&functional protection			water-lackage delay protection,high and low pressure switch, freeze protection device, overheat protection device, overload protection device,phase sequence protection,digital display controller	
Compressor	model		JT335DA-Y1L	
	type/manufacture		hermetic scroll / DAIKIN	
	COP		3.17	
	quantity	set	1	2
	power input	KW	10.7	10.7
	rated power	KW	10.1	10.1
	power supply		3PH, 380V, 50Hz	
	running current	A	15	15
	starting current	A	142	142
	oil type		MINERAL	MINERAL
	oil charge	ml	3000	3000
	crankcase heater	W	40*2	40*2
	weight	kg	71	71
	rated speed	rpm	2900(50Hz)	2900(50Hz)
Fan	type		axial flow	axial flow
	quantity	set	1	2
	rated power	KW	0.75	0.75
	running current	A	2.5	2.5
	Air flow	m3/h	13000	13000
	Fan speed	rpm	720	720
External dimension	length	mm	2215	2215
	width	mm	1100	1100

HAIER CHILLER

	height	mm	1920	1920
Refrigerant charge		kg	10	10*2
Refrigeration system (circuit quantity)			1	2
Refrigeration control method			thermostatic expansion valve	
Water side heat exchanger			shell & tube heat exchanger, working pressure 1.0MPa	
Air side heat exchanger			cross finned coil, inner grooved copper pipe&dydrophilic aluminum finned coil	
Water flow		m ³ /h	6	12
Water resistance		kPa	80	80
Water pipe diameter		mm	65	65
Noise level		DB/(A)	63	65
Net weight		kg	560	800
Running weight		kg	660	925
Casing			polyester painted galvanized steel plate, ivory white	

Nominal working condition (cooling):water inlet temp. 12℃, water outlet temp. 7℃, ambient temp. 35℃

Nominal working condition (heating):water inlet temp. 40℃, water outlet temp. 45℃, ambient temp. (DB)7℃, (WB)6℃

The permitted range of voltage is 380±10%

In the unit there are two protector, air breaker for compressor motor is GV2-M22C,whose parameter is overload current:20~25A,short circuit current:327A,415V; air breaker for fan motor is GV2-M08C, whose parameter is overload current:2.5~4A,short circuit current:51A,400V.

The noise level will be measured in the third octave band limited values, using a Real Time Analyser calibrated sound intensity meter. The noise level is measured at 2meter in front of the unit, 1.5 meter high to the ground.

When starting up the complete unit, the compressor will start up one by one and will not start up together.

4.Dimension data

4.1 Installation dimension

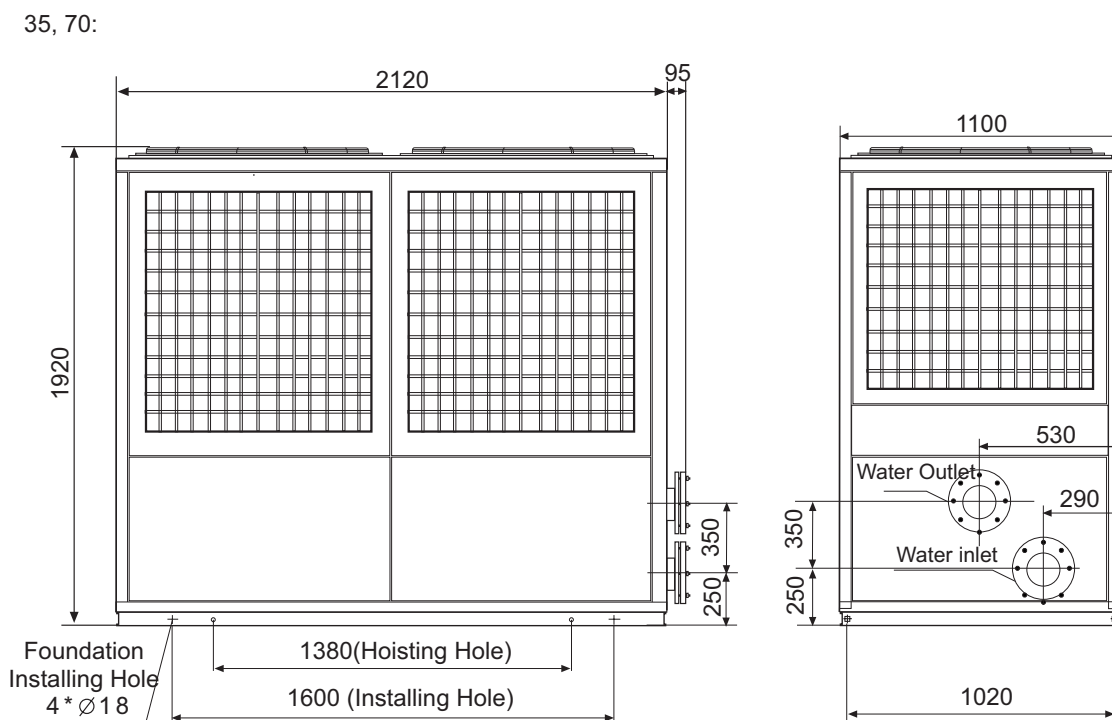

4.2 Foundation dimension

4.2.1 The bearing capacity of the foundation shall be designed according to the unit's operation weight.

4.2.2 The foundation can be beam channel (designed by the installer according to the unit outline dimension) or concrete structure, and the surface of the foundation shall be flat.

4.2.3 A 10~20mm rubber anti-vibration cushion shall be used between unit and foundation.

4.2.4 The unit can be fixed on the foundation by using anchor bolt with 16 or 18mm diameter.

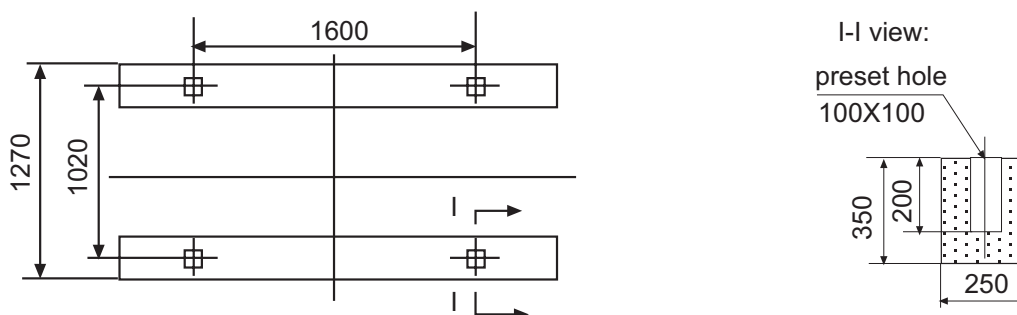

5. Installation and debugging

5.1 Freight Check

All the units are tightly fastened on the wooden pallet by the bolts. Before leaving factory, the units are all checked and pre-filled with refrigerant and refrigerant oil, both of which are the precise amount the unit operation needs. When user receives the product, he shall check it carefully to confirm if there is product damage in transportation and to confirm all the pre-ordered parts are received.

If there is any damage, he shall immediately inform the transportation person and claim for compensation according to relevant clauses. If there is problem except for surface damage, he shall immediately inform our company.

5.2 Transportation

In order to be convenient to carry the unit, the user shall use forklift or crane. When using crane, there shall be proper partition to protect the top and side panel of the unit (as Figure shown). During carrying, the unit shall be kept level, and the gradient shall not exceed 30° . Try to avoid units damage due to improper operation.

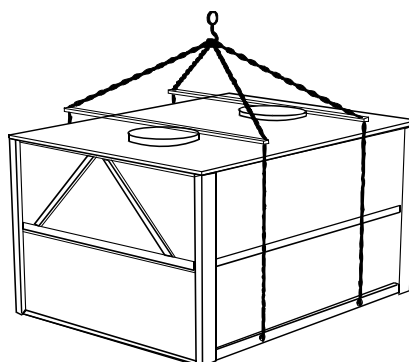

5.3 Unwrap the packaging

After putting the unit on the site, cut the packing strap and remove the outer crate. Unscrew the tightening bolt and remove the wood pallet from the bottom of the unit.

5.4 Selection of Installation Place

5.4.1 The installation place shall be plane, the foundation surface shall be flat, and the supporting surface can bear the operating weight of the unit.

5.4.2 The unit shall not be installed in a place where there is too much dust, corrosive gas, high humidity or insects gathers easily, fallen leaves and other contaminative matters.

5.4.3 There shall be over 1.5m space around the unit to be convenient for ventilation and maintenance.

5.4.4 Try to keep the unit away from sunshine and rain, it is recommended to cover the unit with shed, but be sure there is a space over 3m above the air outlet for releasing heat easily.

5.4.5 An anti-vibration cushion about 10-20mm shall be equipped between the unit and the foundation. After adjusting length, fasten the anchor bolt.

5.4.6 For the heat pump unit, there shall be a drain for the condensate.

5.4.7 The installation and thermal insulation of the water pipes of the air conditioning system shall be designed and instructed by the professionals and shall implement the relevant regulations of the Installation Standard for HV & AC.

5.4.8 The external water pipe system must be equipped with anti-vibration hose, water filter, electronic water cleaner, check valve, drain valve, discharging valve, stop valve and expansion tank, etc. The expansion tank shall be installed 1-1.5m higher than the system top, and its capacity is about 1/10 of the total water amount of the system. The air release valve shall be installed between the top of the system and the expansion tank, and the water tank and the pipe shall be thermal insulated.

5.4.9 The water supply system must match the water pump with proper water flow and proper head to ensure the supply for the unit normally.

5.4.10 The unit must be equipped with a water filter in front of the water inlet pipe and use the mesh with 16~40-mesh filter.

5.4.11 The anti-vibration hose must be used between water pump and unit, between water pump and water pipe of system. At the same time, the pipes and the water pump shall have bracket to prevent the unit from receiving force.

5.4.12 leaning and heat preservation of system must be done before connecting the pipe with the unit.

5.4.13 Recommend that maintenance space among units should be over 400mm.

6. Safety Precautions

6.1 The system pressure and electric parts will cause danger to the installation and maintenance of the air conditioner, so only the authorized personnel with qualification can perform the installation, operation and maintenance of the air conditioner.

6.2 Please comply with the protection measures and safety warnings marked on the documents, labels and nameplate on the unit.

6.3 Please comply with various safety regulations, wearing safety glasses and working gloves, and when welding, wear the fireproof clothes.

Warning: Before maintaining the unit, cut off the main power supply of the unit, otherwise electric shock will cause.

6.4 When maintaining, only the original parts shall be used and pay attention to correct installation, and the parts must be installed in their original position.

6.5 During unit operation, the temperature of some parts of the refrigerant circuit may exceed 70°C, so that the untrained personnel shall not make bold to remove the protection panel of the unit.

6.6 Unit shall not be installed in the air containing explosive gases.

6.7 If the heat pump type unit operates under the condition below 0°C, it must be installed in a place 300mm higher than the ground, which can not only prevent the bottom plate from freezing, but also prevent the accumulated snow from reaching this height to influence the unit's normal operation. The unit shall be installed on a flat surface (the max. deviation of the ground level shall not exceed 2mm/m.)

7. Refrigerant system

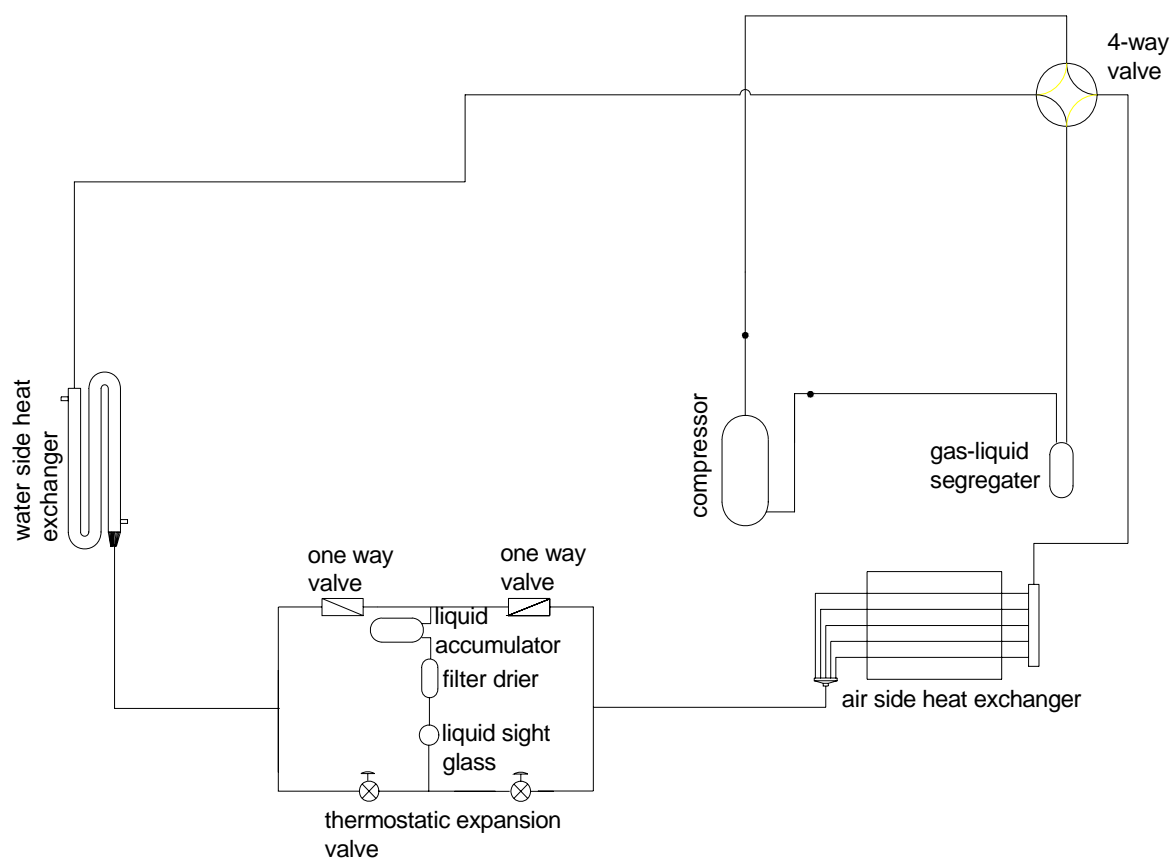

8. Water system installation diagram

Water System Installation Diagram

Diagram of water pipe connection between two units

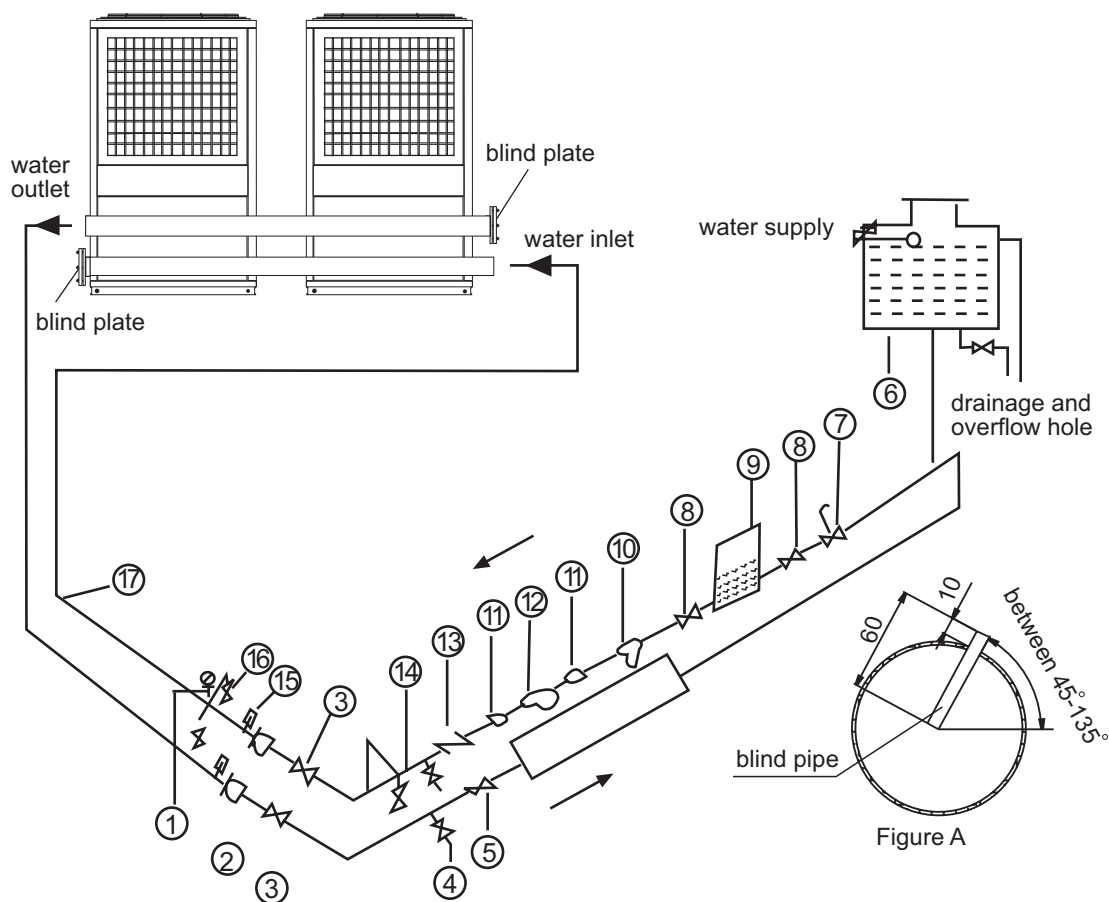

Note:

- | | | |
|--------------------------|--------------------------------|---|
| 1- Pressure gauge | 2-Flexible hose joint | 3.5.8.16-Stop valve |
| 4. Drainage valve | 6-Expansion tank | 7-Auto discharging air valve (highest in the water system) |
| 9-Water container | 10-Water strainer | 11-Flexible joint |
| 13-Check Valve | 14- By-pass Valve | 12-Water Pump |
| 15- Thermometer (0-100℃) | 17-General Water return sensor | |
- blind pipe (Ø8, L=60mm, see Figure A for the structure.)

When cycle water runs for the first time, close the inlet/outlet valve (No. 3) and open the by-pass valve (No.14). When water pump works for a while, clean the water strainer. After confirming that there is no impurity in the external cycle system, open inlet/outlet valve (No. 3) and close the by-pass valve (No.14). Then, the unit is in normal operation.

Note:

In the case of multiple modules combination, water system is controlled in parallel mode, and the general water return temperature sensor in the main module must be fixed on the general water return pipe. Pay attention that a section of blind pipe (Ø8, L=60mm) be reserved for the installation of temperature sensor in site design and that the insert length of blind pipe is 50mm. When installing the sensor, place the sensor beneath the blind pipe and inject some refrigeration oil into the blind pipe. The level of the refrigeration oil should be at least 10mm over the sensor. To minimize heat transfer error, it is necessary to adopt heat insulation measures.

Pipe dimension: the pipe dimension will be different according to the module quantity. Please install as follows:

70+35, 70*2→DN65; 70*2+35, 70*3→DN80;
70*3+35~70*5→DN100;70*5+35, 70*6→DN125.

Water pipe direction: when module quantity is below 3 sets, select the connection of single row type or multi-row type; but when module quantity is no less than 4 sets, must select the single row type connection.

9. Auxiliary electric heating function control

The auxiliary electric heating function will be performed in low ambient temperature. Connect the water inlet/outlet pipe with auxiliary electric heater to the total water inlet/outlet pipe, in the electric control box of the master module, there is the control port of auxiliary electric heating (only with 220V output, not supply the electric heating control part). After compressor starts up, when the actual ambient temp. is lower than the “electric heating startup temp. “ (factory set parameter B7), and water outlet temp. is lower than “heating set temp. “ – “ temp. difference of electric heating startup” (factory set parameter B8), if the two conditions can be met, electric heating will work. When the actual ambient temp. is higher than “ ambient temp. of allowable electric heating startup” or compressor stops, the electric heating will stop.

10. Water pump operation control(valid when water pump and the unit controlled simultaneously)

In the electric control box, there is the freezed water pump simultaneous control port (only with 220V output, not supply the water pump control part). When the unit is in standby state, water pump will not start up; when the unit enters working state from standby state, start up water pump firstly; when the unit enters standby state from working state or stop state, 30seconds later, water pump will stop automatically. In stop state, when water outlet temp. is no more than 3 degree and more than 2 degree, the water pump will start up; when water outlet temp. is no more than 2 degree, start up one module in heating and stop until water temp. arrives 8 degree.

Note: When multiple units utilize one set of water system, as long as the units start up, all the water pumps will start up (except for the spare water pump), and forbid to confirm the water pump quantity according to the running unit quantity. The actual water flow should be in the range of (rated water flow $\pm 30\%$).

11. The terminal simultaneous control

Connect the passive N.O. port of the terminal controller to the simultaneous control port (YK) in the wired controller of the master module unit. When the unit is running and the controller is in simultaneous control state, when one of terminal unit starts up, the chiller system will start up automatically. When all the terminal units stop, the chiller system will stop later.

When in electric wiring, please pay attention to the following:

- a. The wires are the power supply cable and the communication wire. The wires with the unit have been fixed properly, and should not be modified by the user.
- b. Ensure that the communication wire is earthed on one point after the unit is earthed well; if the unit is not earthed properly, the communication will be interfered. The communication wire should be twisted-pair, with diameter AWG20~22, and over 10cm far from the high voltage wire.

The unit running current is as below table:

model	Rated current	Max. current	Rocked current	Cable section for reference
CA0070*	35A	45A	(130*2)A	5*16mm ²
CA0035*	17.5A	22.5A	130A	5*8mm ²

12. Wiring diagrams

a. The unit wiring diagram

35:

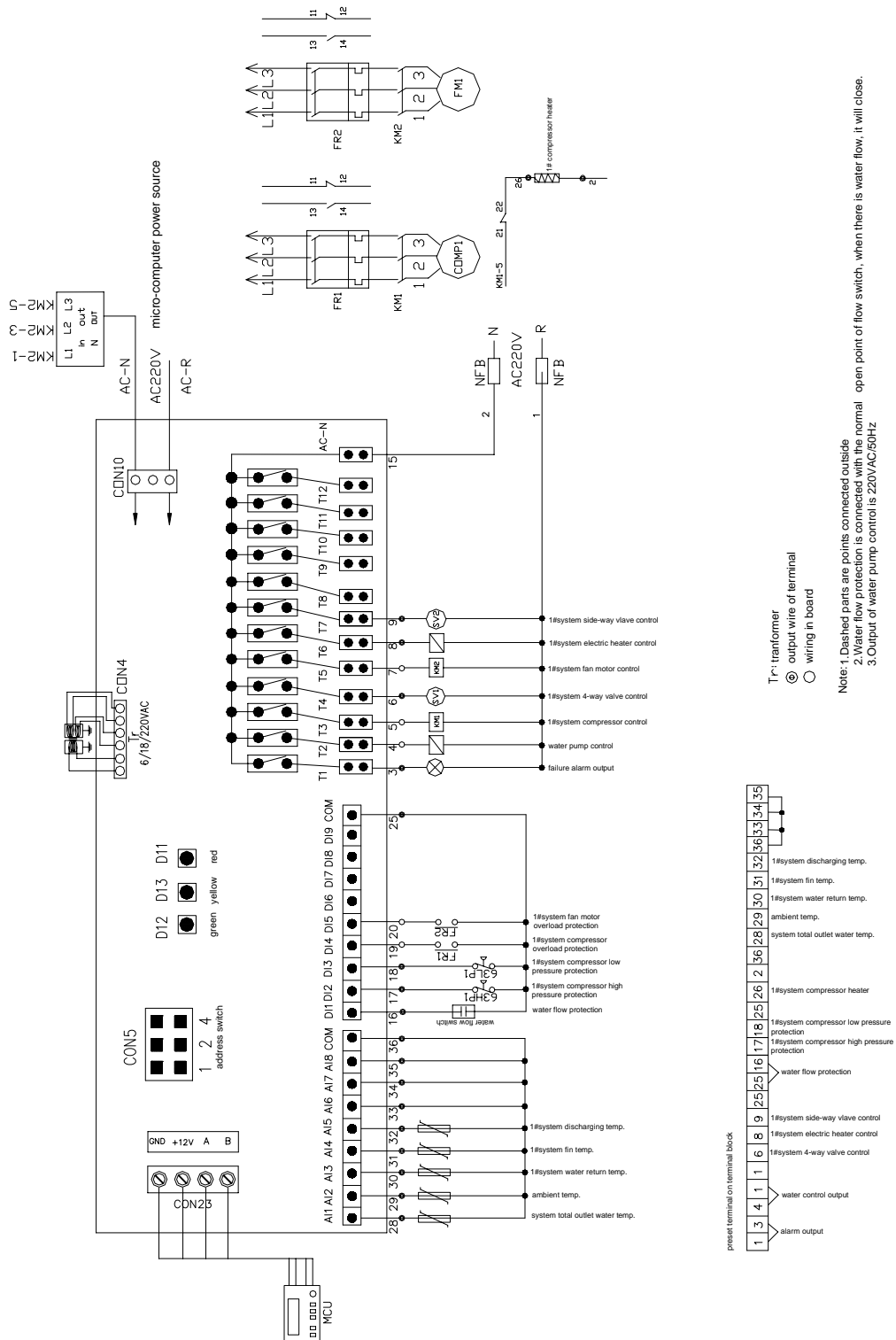

70:

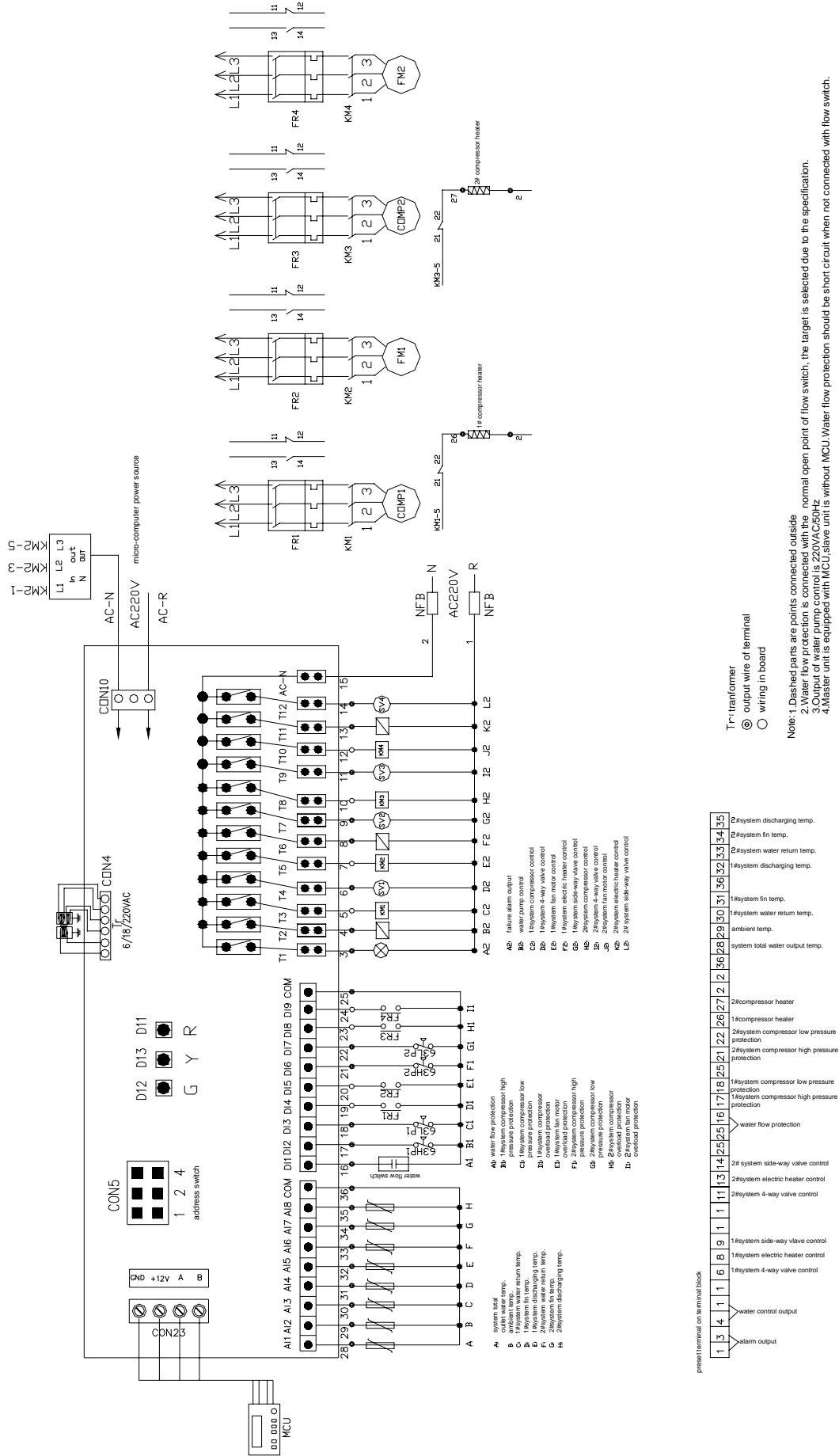

b. The driving wiring diagram

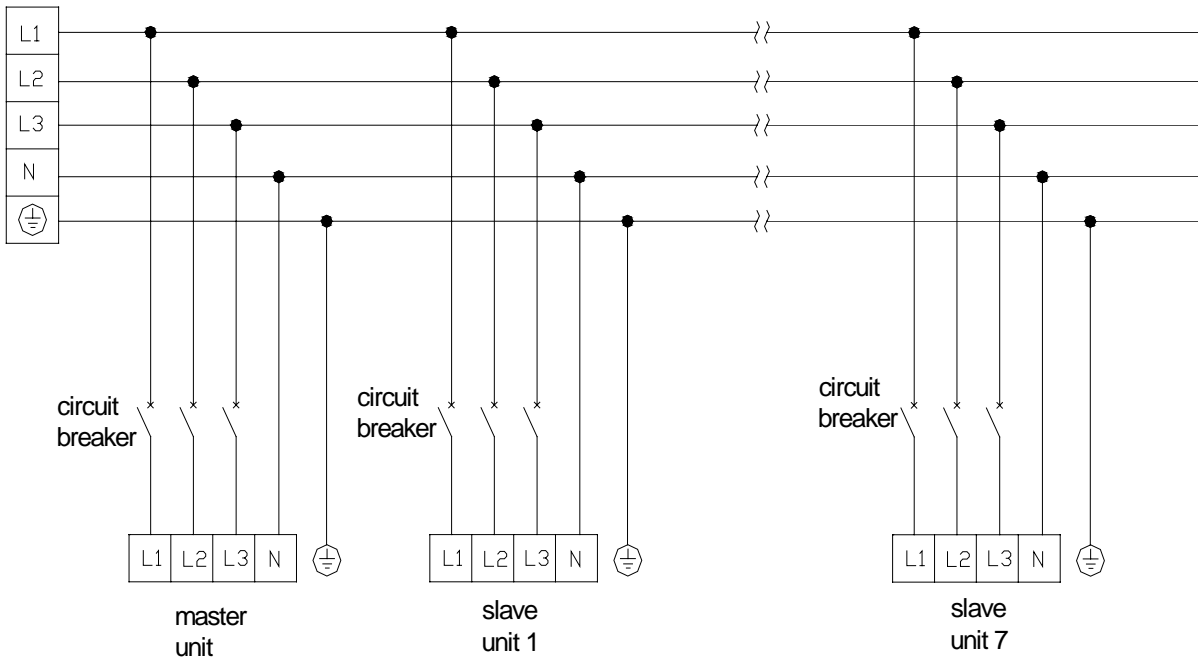

13. Wired controller functions

The unit controller consists of one set of UHR-821 type wired controller and single module or multiple modules composed of 1~8 pieces of UHR-820 type control board.

UHR-820 type control board can control 2 sets of compressor system in one module.

13.1 Control composition

The control system consists of control board (1~8 pieces, with connector), wired controller (1 piece), special power supply transformer (1~8 pieces), 3-core or 4-core communication cable (length depended on the installation distance of module and wired controller, the max. communication distance is 1.3Km), temp. sensor (8 pieces for every control board), failure detecting part (9 pieces in one control board).

13.2 Control function

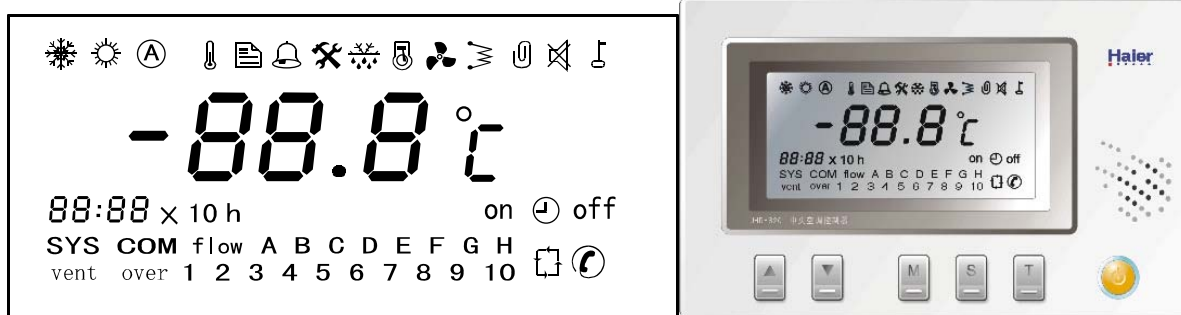

Operation buttons:

▲, ▼, M, S, T, ⏻

	Sign	Operation function
1	⏻	Power on, switch on, switch off, power off
2	▲	Increase, manual reset (2 combination), factory parameter set (3 combination)
3	▼	Reduce, manual reset (2 combination)
4	M	Mode selection, auto-restart setting, factory parameter set (3 combination) and confirm
5	S	Parameter setting, adjust clock, query malfunction, password and code confirmation
6	T	Temp setting, query temp, factory parameter set (3 combination), parameter setting shaft

- ❄️ Cooling sign. In standby state, press button M, and when the cooling sign flashes, press button S to confirm. Thus the wording mode is set to cooling mode.
- ☀️ Heating sign. In standby state, press button M, and when the heating sign flashes, press button S to confirm. Thus the wording mode is set to heating mode.
- Ⓐ Auto-mode sign. In standby state, press button M, and when the auto sign flashes, press button S to confirm. Thus the wording mode is set to auto mode. In auto mode, the system will adjust to enter the cooling/heating mode according to the difference between the cooling/heating changeover temperature and the water return temperature.
- 🌡️ Temperature-setting sign. In standby or running state, press button T to enter the water return temperature setting mode, the sign will flash. Adjust the temperature with button ▲/▼ and confirm with button S to quit the setting mode.
- 📄 Factory parameter-setting sign. Enter the password of the factory parameter setting, and then you can enter the factory parameter- setting mode.
- 🔔 Alarm sign for malfunction signal. This sign with the other signs together can indicate all kinds of malfunctions such as communication, water flow, high pressure, low pressure, compressor overload, fan motor overload, discharging overheat, temperature sensor failure, etc.
- ⚠️ Alarm sign for serious malfunction. When a consumable malfunction signal appears 3 times within 30 minutes, the serious malfunction sign will flash to hint that you only can reset in manual after maintenance.
- ❄️ Defrosting sign



Compressor operation sign



Fan motor operation sign



Electric heating operation sign



AUTO RESTART sign. When the system is set at AUTO RESTART mode, if the power supply is cut down, when the power comes back again, the system will resume the operation mode before the power is cut down.



Wired controller buzzer closed sign



Hint sign of password input. When modifying the factory parameter, the password must be filled in.



Fan coil simultaneous control sign. The system can be set to start up following the fan coil startup.

When one of fan coils is started up, the system will be started up too. When all the fan coils stop, and after a while, the system will stop automatically. Also the system can be connected to a remote control switch.



Telephone remote control sign. If the wired controller is equipped with a remote control card, it can realize the telephone remote control function.

88:88 x 10 h Time sign. It can display the real time and the auto switch on/off time, also it can display the parameter when setting the parameter and querying the parameter.

on  off Auto switch on/off and clock sign. It is used to set the switch on/off and the real time clock.

SYS COM flow A B C D E F G H Indication sign, SYS is used to indicate the module of the system (plus A, B, C, D, E, F, G, H), COM is used to indicate the communication failure (plus A, B, C, D, E, F, G, H), flow is used to indicate the flow failure (plus A, B, C, D, E, F, G, H).

vent over 1 2 3 4 5 6 7 8 9 10 Indication sign, vent is used to indicate the discharging temperature overheat (plus A, B, C, D, E, F, G, H or 9, or 10); over is used to indicate the compressor or fan motor overload (plus the corresponding signs).

13.3 I/O port description of UHR-820S control board

Fin temp. sensor model: DTN-C502H3T-ACU123B 5K Ω B=3470

Discharging temp. sensor model: DTN-G514H8A-ACU104H 50K Ω B=4450

AI1: system total outlet water temp.;

AI2: ambient temp.;

AI3: 1# system water return temp.;

AI4: 1# fin temp.;
AI5: 1# discharging temp.;
AI6: 2# water outlet temp.;
AI7: 2# fin temp.;
AI8: 2# discharging temp.;
DI1: water flow protection;
DI2: 1# system compressor high pressure protection;
DI3: 1# system compressor low pressure protection;
DI4: 1# system compressor overload protection;
DI5: 1# system fan motor overload protection;
DI6: 2# system compressor high pressure protection;
DI7: 2# system compressor low pressure protection;
DI8: 2# system compressor overload protection;
DI9: 2# system fan motor overload protection;
T1: failure alarm output;
T2: water pump control;
T3: 1# compressor control;
T4: 1# 4-way valve control;
T5: 1# fan motor control;
T6: 1# electric heater control;
T7: 1# side-way valve control
T8: 2# compressor control;
T9: 2# 4-way valve control;
T10: 2# fan motor control;
T11: 2# electric heater control;
T12: 2# side-way valve control;
AC-N: AC neutral wire N.

13.4 Remote communication port

There are four wires between the wired controller and the control board of the master unit, which are GND, +12V, A, B.

There are 3 wires among the control boards, which are GND, A, B.

The communication type between the wired controller and the control board is RS-485. There is a remote control port and the independent system alarm output port (current >5A/220V AC) in order to control the unit ON/OFF for the exterior connected system (or the fan coil simultaneous control switch) and for the exterior alarm equipment.

13.5 LED indication on the wired controller

Failure (red), cooling (green), heating (yellow) , auto(orange)

13.6 LED indication on the control board and the control ports

There are the power LED 1 (VD, green), power LED 2 (+5V, yellow), operation LED (OP, red) on the control board, which are used to indicate the power is normal (LED is on) and module operation is normal (LED will flash slowly, when failing, it will flash quickly). Every relay has a corresponding LED (green) on the control board, when the LED is on, the corresponding relay will be closed. On the control board there are a manual compulsory defrosting button.

14. Operation introduction

14.1 Start up

Press continuously power button for 3 seconds, LCD will display the product serial number (the default value 00 00), the unit enters the standby state and the LCD will display the system water return temperature, then water pump will start up.

14.2 Mode selection

Press button M to select the mode: cool, heat, auto, and press power button to confirm, the corresponding icon will flash, 3 minutes later, start up the relative unit due to the set temperature and LCD will display the indication of the running unit.

14.3 Temp. setting (water return temp.)

Press button T to enter the temp. setting of a certain mode, the previous temp. will display and flash, press button \wedge/\vee to modify the temp., and press T again to quit.

14.4 Query the temperature

Press button T for a long time, LCD will display the module No. (e.g.: SYS A), then press T quickly to the temp. query state. Press button \wedge/\vee to check the 1~8 temperatures; press T to quit or 30 seconds later quit automatically.

14.5 Query the failure

Press button S for a long time to query the failure. When failure occurs, LCD will display the icon, module No. and the failure code.

14.6 Timer ON/OFF and CLOCK adjustment

Press button S quickly to the set state, then press button \wedge/\vee to select timer on, timer off, or clock, further, press S to confirm the selection. Press button \wedge/\vee to modify the first digit, press T to move to the

second digit, after modifying all the values, press S to confirm and quit.

14.7 Setting of protection on field, fan coil simultaneous control and telephone remote control functions

Press button M for a long time, LCD will display the icons of protection on field, fan coil simultaneous control and telephone remote control functions. Press button ∇ to activate the protection on field; press button S to activate the fan coil simultaneous control function; press button T to activate the telephone remote control function (equipped with the telephone connecting card), press M to confirm the selected function.

14.8 Manual reset after troubleshooting and clear the alarm

After some malfunctions have been resolved, the unit only can be reset by pressing buttons \wedge/∇ simultaneously. When a resumable malfunction signal appears 3 times within 30 minutes, the serious malfunction sign will flash to hint that you only can reset in manual after maintenance.

When failure occurs, the red indicator on wired controller will flash, and the wired controller will alarm, the relay will act. Press buttons \wedge/∇ to cancel the alarm, LCD will display the cancelling icon.

14.9 Factory parameter setting

In standby state, press buttons \wedge , M, T simultaneously to enter the factory parameter setting mode. There will be parameter setting sign and password. The default password is 00 00, press button S to confirm. Fill in the correct password and confirm, the parameter code will display and can be selected their first letter (A, B, C, D, E, F) with buttons \wedge/∇ ; you can select the number with button S, then you can modify the parameter with the buttons \wedge/∇ , press button M 2 times and quit.

1)	Type A----defrosting condition	Default value	Setting range
1.1	A1 permitted defrosting operation time	5 min	1~20 min
1.2	A2 defrosting interval time 1	30min	10~60 min
1.3	A3 defrosting interval time 2	40min	10~60 min
1.4	A4 fin temperature after finishing defrosting	25°C	10~30°C
1.5	A5 temperature difference between permitted defrosting temp and the condenser fins	8°C	3~15°C
1.6	A6 dividing point of ambient temperature between two kinds of defrosting interval time	5°C	1~20°C
2)	Type B - working temperature		
2.1	B1 return difference of cooling temperature control	3°C	1~10°C
2.2	B2 return difference of heating temperature control	3°C	1~10°C

HAIER CHILLER

2.3	B3 permitted minimum temperature of out water in cooling	4°C	0~5°C
2.4	B4 permitted max. temperature of out water in heating	80°C	50~90°C
2.5	B5 ambient temperature limit in cooling	10°C	1~10°C
2.6	B6 ambient temperature limit in heating	25°C	10~30°C
2.7	B7 ambient temperature permitting starting electric heating	12°C	5~20°C
2.8	B8 temperature difference between electric heating start and stop	8°C	3~15°C
3)	Type C - protection		
3.1	C1 high pressure malfunction protection temperature	125°C	85~135°C
3.2	C2 high pressure malfunction resume temperature	60°C	50~80°C
3.3	C3 malfunction auto resume time	4s	2~20s
3.4	C4 water pump malfunction detection time delay	4s	2~20s
3.5	C5 low voltage malfunction detection time delay	5s	2~20s
3.6	C6 fan motor overload malfunction detection time delay	5s	0~20s
3.7	C7 compressor overload detection time delay	5s	0~20s
4)	Type D - working parameter		
4.1	D1 temperature adjustment period	1min	1~4min
4.2	D2 time interval of external equipment action	3s	2~20s
4.3	D3 protection signal shield byte	00	
4.4	D4 temperature undetected byte 0 air discharge 1 out water	00	
4.5	D5 when cooling, the unit not checking the ambient temperature	00	0: checking 1: no checking
5)	Type E - password setting		
5.1	E1 factory password	Product serial No.	
5.2	E2 decode 1	12 34	
5.3	E3 decode 2	12 34	
5.4	E4 trial run period 1	9999×10h	EE EE shows invalid
5.5	E5 trail run period 2	9999×10h	EE EE shows invalid
5.6	E6 accumulated working time	00 00×10h	
5.7	E7 product serial number setting	00 00	0000~9999
6)	F type-Module Number Setting	A	(ABCDEFGH)

15. External wiring of UHR-820 type control board

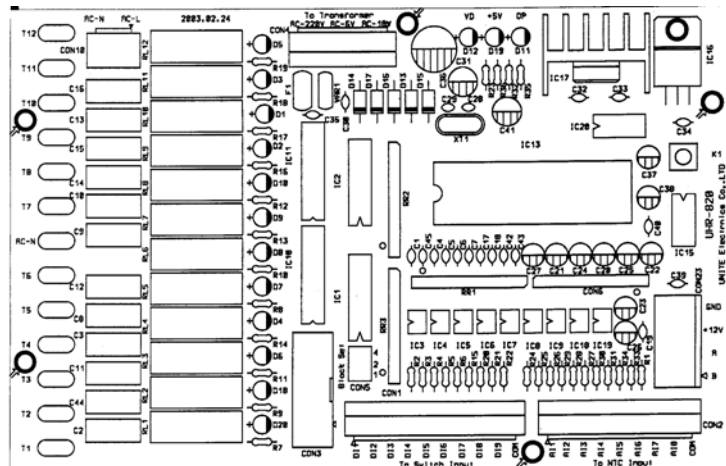

15.1 Wiring description

15.1.1 Communication port (MB312-508 type 4-wire 5.08mm terminal)

Connect the same terminals of GND, A, B terminals of the wired controller and the module control board in parallel and only connect the +12V on control board of the master module (address is 0) to the same terminal (+12V) on the wired controller.

15.1.2 Temp. sensor port (VH-2 type 9-wire 3.96mm socket)

Totally 8 pieces of temp. sensors, herein, 2 pieces of compressor discharging temp. sensor are specially high temp. sensor (model: DTN-G514H8A-ACU104H 50K Ω B=4450); the others are normal temperature sensors (model: DTN-C502H3T-ACU123B 5K Ω B=3470). One end of the sensors is connected to the relative port, the other end is to the COM port.

15.1.3 Protection signal port (VH-2 type 10-wire 3.96mm socket)

Totally 9 ways of protection signals, which are ON/OFF signal, normally, they are connected, while in failure, they are disconnected. One end is to the COM port, while the other end is to the relative port.

15.1.4 Relay output port (11 pieces of 6.35*0.8mm lug)

Port marked with AC-N must be connected to the neutral wire of power supply circuit (allowable max. current is 30A), the others are respectively to N terminal of the AC contactor.

15.1.5 AC power supply input port of control board (VH-2 type 3-wire 3.96mm socket)

Input AC voltage 220V, current >0.1A. Pay attention that the phase wire and the neutral wire cannot be fixed improperly, and the power supply of the phase wires and the contactor should be the same. Otherwise, the anti-interference of controller and the relay life will be affected.

15.1.6 Power supply transformer port (VH-2 type 6-wire 3.96mm socket)

The two ports marked with AC-220V are connected to the primary winding of transformer; The ports marked with AC-6V and AC-16V are connected to the secondary winding of transformer.

16. Control functions

16.1 Control type for cooling and heating

The system will adjust the temperature according to the water outlet temperature of the master module. The wired controller will control the compressor on/off according to the difference between the water outlet temperature and the set temperature.

In cooling mode, if the water outlet temperature is higher than the set temperature, the system will start up one compressor. After waiting for a control cycle (can be set by factory parameter D1), if the water outlet temperature is still higher than the set temperature, the system will continue starting up a second compressor in cooling mode. The others will be deduced as the analogy.

If the water outlet temperature is lower than the set temperature (factory parameter B1), the system will stop that compressor firstly. After waiting for a cycle, if the water outlet temperature is still lower, the system will stop a second compressor. The other will be deduced as the analogy.

The heating control principle is as the same as that of cooling mode, the only difference is that it uses the factory parameter B2.

16.2 Interval of startup/stop of the water pump and compressor, and the startup/stop of 4-way valve and fan motor

In standby state, the water pump will not start up. As soon as entering the running state, the water pump will start up firstly. When changing from the running state to standby state or shutoff state, water pump will stop automatically 30 seconds later.

The min interval is 3 minutes from stop to the next startup. And 3 minutes later, the first compressor will startup. In order to balance the compressors running time, in the condition of 3 minutes interval, the compressor will work in turn according to the principle: who not startup will startup earlier, who startup earlier will stop earlier.

Compressor, 4-way valve, fan motor, etc exterior equipments will comply with the "interval of external equipment action" (D2) to stop/startup one by one.

16.3 The temperature limitation of water outlet of cooling and heating mode

"Permitted minimum temperature of out water in cooling" (B3) and "Permitted maximum temperature of out water in heating" (B4) are used to make the protection system work normally in the permitted condition.

16.4 Ambient temperature limitation of cooling and heating

"ambient temperature limit in cooling" (B5) and "ambient temperature limit in heating" (B6) are the limitation parameters to protect the system normal operation.

16.5 Condition of electric heater start/stop

After the compressor startup, when the real ambient temperature is lower than the startup temperature of

electric heater (B7), and also the water return temperature is lower than the difference between “the set temp. in heating” and “the temp. difference of electric heater startup”, if the above conditions are met, electric heater will startup. When the real ambient temperature is higher than “the ambient temperature of permitted electric heater startup”, or the compressor stops, the electric heater will shut off.

16.6 Defrosting control

In heating mode, if the system meets the defrosting condition, it will permit one compressor to defrost. If the ambient is lower than “ambient temperature of two kinds of defrosting time interval” (A6), the interval of one compressor for two defrosting is “defrosting interval time 1” (A2); if the ambient is higher than A6, the interval of one compressor for two defrosting is “defrosting interval time 2” (A3).

If for one compressor unit of a certain module, the temperature difference between the real ambient temp and condenser temp is higher than “temp difference between permitted defrosting temp and the condenser fins “(factory parameter A5), and also if it has met the interval for the second defrosting, this unit will enter the defrosting mode, meanwhile, the corresponding bypass valve will open.

When the total defrosting time has arrived the set value of “permitted defrosting time” (A1), or when the temperature of the condenser fins has increased to the set value of “fin temperature after finishing defrosting”, this unit will quit the defrosting mode.

16.7 Protection signal

Every module is with 9 ways of ON/OFF protection signal to protect the compressor, fan motor and the flow switch. For the failures such as water flow (C4), low pressure in refrigerant circuit (C5), fan motor (C6), compressor overload (C7), the unit can set different delay to adapt the device.

“discharging abnormal protection temp.” (C1) is used to avoid compressor discharging temp. over heat. When discharging temp. exceeds the set value, the relative compressor and fan motor will stop; when discharging temp. is below “discharging abnormal resume temp.” (C2), the relative module will quit the protection.

When temp. sensor is abnormal (open circuit or short circuit), the relative module will stop. When the water return temp. sensor of the master module is abnormal, the whole system will stop.

“malfunction auto resume time” (C3) is used to set the reasonable time to resume the unit after the failure is eliminated, to avoid the frequent start/stop.

When the communication between a module and the wired controller is abnormal, the module will stop. The communication failure code and the relative module code will display on the wired controller.

16.8 Anti-freezed function

In switch off state, when water outlet temperature is lower or equal 3°C, and over 2°C, the water pump will

start up; if water outlet temperature is lower or equal 2°C, one module will start up in heating, until the water temperature reaches 8°C, it will stop heating and quit the anti-freezed mode.

17. Controller specs

Rated working voltage: 220±20% VAC; power consumption<10VA.

Ambient temp.: -15~60°C; relative humidity≤90%, no dew.

Working mode: continuous operation.

Average non-malfunction working time:>5000hrs.

Control board external dimension: (L*W*H):165*105*28mm.

Panel dimension of wired controller (L*W*H): 160*98*11.5mm.

18. Malfunction and troubleshooting

Malfunction	Probable reasons	Solution
Wired controller can not start up	<ol style="list-style-type: none"> 1.Phase sequence of the main power is wrong 2.The voltage of main power does not meet the request 3.The communication wire is connected badly 	<ol style="list-style-type: none"> 1.Change the phase sequence of the main power 2.Adjust the voltage of the main power 3.Connect the communication wire again
Unit can not start up after start up a long time	<ol style="list-style-type: none"> 1.The set temperature is too high 2.The water outlet temperature sensor is damaged or not fixed well 3.The wired controller is set as the fan coil simultaneous control, but in fact it do not adopt this mode 4.Control wire is fixed well 	<ol style="list-style-type: none"> 1.Lower temperature 2.Press the sensor firmly or change the sensor 3.Cancel the fan coil simultaneous control function 4.Press the control wire firmly
Suction pressure is too high	<ol style="list-style-type: none"> 1. Thermal load is too big 2. Open degree of expansion valve is too large 	<ol style="list-style-type: none"> 1.Lower load 2.Change expansion valve
Suction pressure is too low	<ol style="list-style-type: none"> 1.Lack of refrigerant 2. Open degree of expansion valve is too little 3.Pipe or filter drier is blocked 4.Evaporating water is too low 5.Evaporator is too dirty 	<ol style="list-style-type: none"> 1.Check the leakage point, recharge refrigerant 2.Change expansion valve 3.Clean pipeline, change the filter drier 4.Adjust the water flow or check the load 5.Clean the dirty
Compressor running is too long, or not	<ol style="list-style-type: none"> 1.Load is too big 2.Temperature is adjusted too low 	<ol style="list-style-type: none"> 1.Check the reason of overload, add the capacity

stop	3.Lack of refrigerant	2.Re-adjust the set temperature 3.Recharge the refrigerant
Discharging pressure is too high	1.Pipe or filter is blocked 2.Refrigerant is too much or there is non-condensed gas 3.Condenser is dirty and heat releases badly	1.Clean pipeline, change the filter drier 2.Release the redundant refrigerant or the non-condensed gas. 3.Clean the condenser
Discharging pressure is too low	1.Lack of refrigerant 2.Compressor failure	1.Recharge refrigerant 2.Change the compressor

19. Water quality management

If the quality of chilled water and cooling water is bad, it not only will cause dirty in the heat transmission pipe, effect the heat exchanging efficiency, lower the unit performance, but also make corrosion in the pipe, which will result in the serious problem. The customer should deal with the water according to the below table. In the chilled water system, the soft water should be utilized. Check the water quality in a certain period; if it cannot pass the requirement, measures should be taken immediately.

	Item	Unit	Recharge water	Chilled (cooling) water	Tendency	
					Corrosion	Dirty
Basic items	PH value (25°C)		6.5-8.0	6.5-8.0	0	0
	conductance (25°C)	μS/cm	<200	<800	0	0
	Chlorine ion (Cl ⁻)	mg Cl ⁻ /L	<50	<200	0	
	Vitriol ion (SO ⁻²)	mg SO ⁻² /L	<50	<200	0	
	Acid consumption (PH4.8)	mg CaCO ₃ /L	<50	<100		0
	Full rigidity	mg CaCO ₃ /L	<50	<200		0
Reference items	Iron (Fe)	mg Fe/L	<0.3	<1.0	0	0
	Sulfur ion (S ²⁻)	mg S ²⁻ /L	/	/	0	
	Ammonium ion (NH ₄ ⁺)	mg NH ₄ ⁺ /L	<0.2	<1.0	0	
	Silicon dioxide (SiO ₂)	mg SiO ₂ /L	<30	<50		0

20. Daily maintenance

Note: Before performing any maintenance and repair to the unit, please cut off power supply.

Electricity leakage will cause body injury.

In order to exert the unit's performance fully, must pay attention to the following items:

1. Electric wire Connection: the power supply provided should be within the compressor permitted range.

Confirm there is no wrong connection in terminals and the main panel of AC contact, etc. Confirm all the electric connections are not loose; all the electric components (AC contactor and relay, etc.) are connected firmly and safely. Especially pay attention to the condition of the connecting wire between control components and electric control box and power cord. The power wire shall not be warped, and the insulation cover shall not have cracks and cut. Check the energy consumption in starting and operating the unit is in the permitted range.

2. Water system Connection: confirm the water system does not leak water. If the unit has not been used for a long period, it is necessary to open the drain valve of the water pump to empty the water pump, tube pipe or shell pipe type heat exchanger and all the water in the pipes. If the ambient temperature may drop below 0°C, it is more necessary to be done.

If the water in the unit is not emptied, the main switch of the power supply must keep close, and the unit is set in heating mode, thus it can prevent from freezing by the heating temperature sensor. Do be careful when cleaning the filter.

3.Cleaning of tube in tube type (or shell&tube type) heat exchanger: when using the unit, for example, when using hard water, sometimes it will produce dirty. In this condition, it is recommended to install the filter to remove dirty. The heat exchanger shall use cleaning solution to be washed; the solution can be weak acid solution, use pump to drive the cleaning solution in the heat exchanger.

The installation of the liquid container for weak acid solution can be permanent or as an optional device. If there is spare connecting pipe, the portable cleaning device can be installed in the pipes at any time.

In order to fulfill a better cleaning effect, the circulation flow speed of the acid solution shall be 1.5 times of normal water flow, if can use acid solution to wash the pipe in an opposite direction again, the effect will be better. Finally, use a large amount of water to repeatedly wash the acid solution clean.

The unit shall be cleaned periodically, not until the unit is blocked. The cleaning frequency is determined by the water quality being used, but generally, once a year is rather reasonable.

4. Refrigerant Circuit: Confirm the refrigerant and refrigerant oil does not leak from the compressor. Check if the pressure in the high/low pressure side is normal. Check the inside cleanness of the plate type heat exchanger by pressure drop.

5.Control: Check the operation of all the delays, high/low pressure protection and control.

MAINTENANCE

1. If needing to replace the refrigerant of the unit, its quantity shall be in accordance with the data on the nameplate. Before replacing, the previous gas must be released as empty as possible.
2. During operation, all the panels must be installed properly, including the panel on the control

box.

3. If it must cut the pipes of the refrigerant circuit, the pipe cutter must be used, do not use the tools that will produce copper scraps. All the pipes of the refrigerant circuit are copper pipes special for cooling.

Sincere Forever

Haier Group

Haier Industrial Park, No.1, Haier Road

266101, Qingdao, China

<http://www.haier.com>



Большая библиотека технической документации

<https://splitsystema48.ru/instrukcii-po-ekspluatacii-kondicionerov.html>

каталоги, инструкции, сервисные мануалы, схемы.